

DESIGN NOTES

24-Bit ADC Measures from DC to Daylight – Design Note 219

Derek Redmayne

The need to measure a wide variety of physical phenomena is increasingly important in intelligent sensors. The following circuit gives eight examples of the flexibility of the LTC[®]2408 for sensing real world phenomena. The eight inputs of the LTC2408 are used here in a variety of ways that would not be practical without the dynamic range of the LTC2408.

All of the examples shown use single-ended sensing and an absolute minimum of external circuitry. Inputs to the circuit shown range from high voltage DC to ultraviolet light. Output data represents amplitude or power levels for signals in all the AC inputs.

LT, LTC and LT are registered trademarks of Linear Technology Corporation. No Latency $\Delta\Sigma$ is a trademark of Linear Technology Corporation.

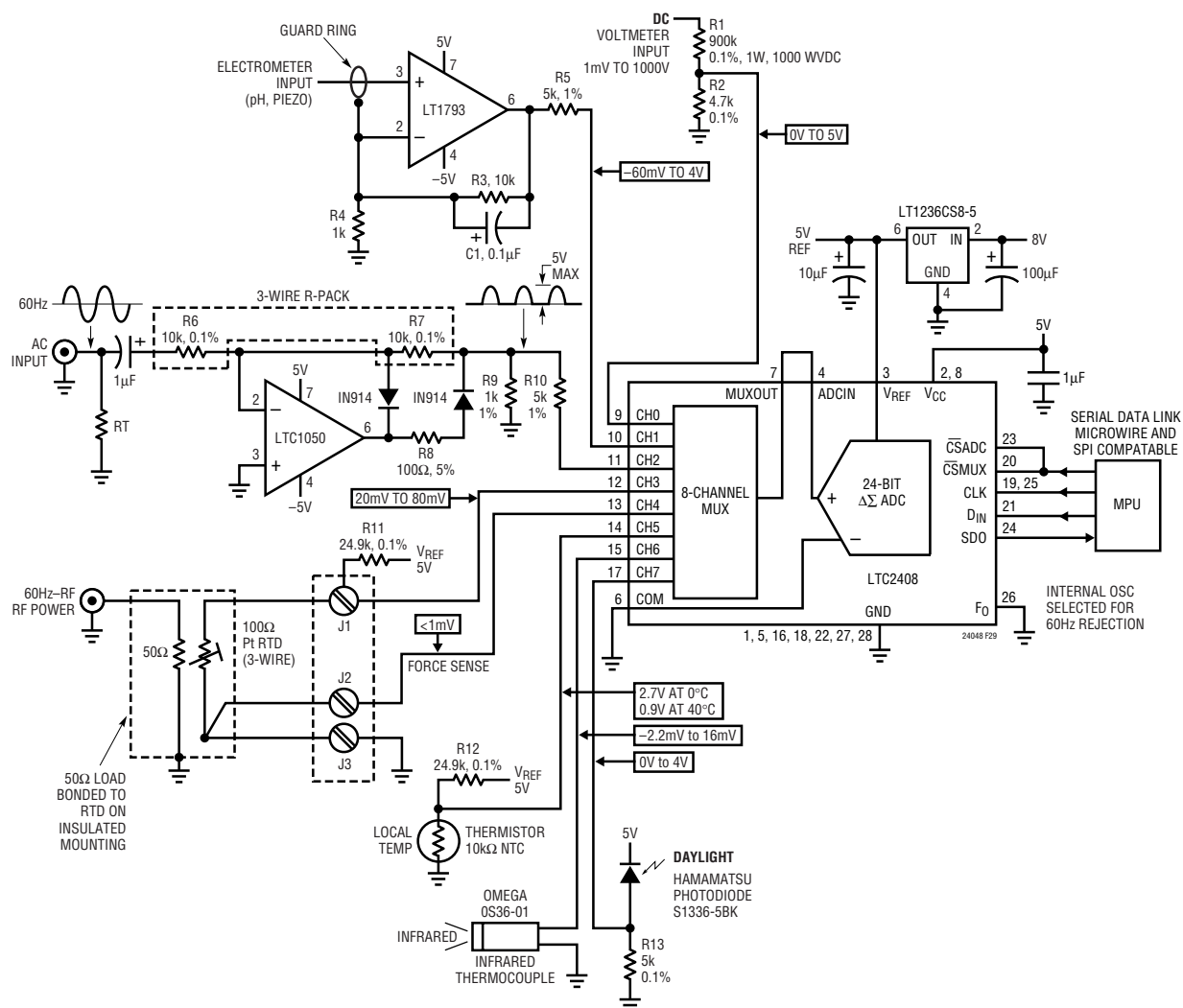

Figure 1. Measure DC to Daylight Using the LTC2408

CH0, with an appropriate 1W resistor rated to withstand 1000V, is able to measure DC voltages over a single range of -60V to 1000V. No autoranging is required.

CH1 shows an LT[®]1792 FET input amplifier as an electrometer for low frequency applications, such as pH. Physical phenomena with very high source impedance cannot drive a switched capacitor converter directly; hence, some form of buffering is necessary.

CH2 shows a precision rectifier that relies on the LTC2408's sinc⁴ digital filter for integration of the resulting half-wave rectified signal. This circuit can be used at 60Hz, 120Hz, and from 400Hz to 1000Hz with good results. Above 1000Hz, amplifier overshoot and gain/bandwidth will start to compromise results. The dynamic range is limited by the LTC1050's offset voltage. The dynamic range of the system is approximately five orders of magnitude as limited by noise. A stable signal source allows parameters such as magnetic reluctance, permeability or eddy current loss to be measured. A second precision rectifier on another channel can be used to provide ratiometric operation.

CH3 and CH4 are used for RTD temperature sensing with a resolution of approximately 0.03°C. CH4 senses the voltage drop on the force lead for 3-wire RTDs. Subtract 2 × CH4's reading from CH3's reading to give the true reading at the sensor. If a 2-wire RTD is located in close proximity to the LTC2408, CH4 can be used for another signal.

The use of an RTD to sense the temperature of a 50Ω load resistor allows true RMS/RF input power to be measured thermally with a fair degree of accuracy from audio to GHz frequencies.

In practice, the RTD must be bonded to an appropriate resistor [noninductive, low TC and able to survive the same temperature range as the RTD (850°C)]; the assembly must then be mounted inside an insulating enclosure that exhibits only direct thermal transfer.

Convection and radiation should be eliminated. The insulating material, filler, adhesives and any substrate material must withstand cycling through these temperature extremes. Resolution in the center of the power range is approximately 1 part in 1000. The maximum temperature of the resistor or sensor, whichever is less, limits the maximum power level that can be measured.

Data Sheet Download

<http://www.linear-tech.com/go/dnLTC2408>

The minimum level that can be resolved is limited by LTC2408 noise (1.5μV_{RMS}). This basic approach to sensing wide band AC can be tailored for high or low power levels. Physical implementation determines the results.

It is best implemented with RTDs and, with less precision, with thermocouples or thermistors. The dynamic range of this technique is not wide, as power is measured, and once translated back to signal amplitude, exhibits a range that is the square root of the dynamic range at the converter.

CH5 shows a half-bridge connected thermistor, used to sense the case temperature of the RTD-based thermal power measurement scheme on channels 3 and 4. Thermistors give very good resolution over a limited temperature range. Resolution of 0.001°C is possible, although accuracy is limited by self-heating effects and thermistor characteristics.

CH6 is directly connected to an infrared thermocouple allowing noncontact measurement of temperature or, alternatively, high levels of infrared light. The resolution of this type of sensor, as used with the LTC2408, is comparable to that of a conventional thermocouple. Resolution with a Type J is ≈0.03°C. The temperature range of these devices is more restricted than a conventional thermocouple and they are tailored for limited ranges. Note that the output impedance of the sensor is 3kΩ. As a result, open-detection schemes typically used with thermocouples cannot be used. These devices do not need cold junction compensation. In addition, conventional thermocouples can be connected directly to the LTC2408 (not shown) and cold junction sensing can be provided by another temperature sensor on a different channel or by using an LT1025 for cold junction compensation.

CH7 is used to sense daylight via photodiode current. With a resolution of 300pA, the optical dynamic range of this circuit covers six orders of magnitude.

This application is intended to demonstrate the mix and match capabilities of the LTC2408, which allow very low level signals to be handled alongside high level signals with a minimum of complexity.

Many other single-ended sensing schemes can be connected directly to the LTC2408. Differential signals can also be accommodated via instrumentation amplifiers, also available from LTC.

For literature on our No Latency $\Delta\Sigma^{\text{TM}}$ ADCs, call **1-800-4-LINEAR**. For applications help, call (408) 432-1900, Ext. 2453